

DC Plain Gouging Electrodes

General purpose electrodes without the copper coatings. Used on applications where copper is considered detrimental. These electrodes contain the same high quality blend of carbon and graphite as other ARCAIR electrodes.

Part No.	Description	STD
21-983-003	5/32 X 12 BARE	50
21-033-003	3/16 X 12 BARE	50
21-043-003	1/4 X 12 BARE	50
21-053-003	5/16 X 12 BARE	50
21-063-003	3/8 X 12 BARE	50
21-083-003	1/2 X 12 BARE	100
21-103-003	5/8 X 12 BARE	100

AC Pointed Copperclad Electrodes

Designed for use with AC power supplies. Rare earth material is added to stabilize the arc, improving the operating characteristics.

Part No.	Description	STD
20-033-003	3/16 X 12 AC-CC	50
20-043-003	1/4 X 12 AC-CC	50
20-063-003	3/8 X 12 AC-CC	50

DC Copperclad Pointed Electrodes

A standard all purpose gouging electrode. Controlled copper coating improves conductivity, providing more efficient, cooler operation and helps maintain electrode diameter at the arc point.

Part No.	Description	STD
22-023-003	1/8 X 12 DC-CC	100
22-983-003	5/32 X 12 DC-CC	50
22-033-003	3/16 X 12 DC-CC	50
22-043-003	1/4 X 12 DC-CC	50
22-053-003	5/16 X 12 DC-CC	50
22-063-003	3/8 X 12 DC-CC	50
22-082-003	1/2 X 14 DC-CC	50

DC Jetrod Copperclad Jointed Electrodes

Eliminates stub loss and provides continuous electrode feed for semi-automatic and automatic Arcair Torches.

Part No.	Description	STD
24-052-003	5/16 X 14 DC-CC	100
24-062-003	3/8 X 14 DC-CC	100
24-064-003	3/8 X 17 DC-CC	100
24-082-003	1/2 X 14 DC-CC	100
24-084-003	1/2 X 17 DC-CC	100
24-102-003	5/8 X 14 DC-CC	100
24-104-003	5/8 X 17 DC-CC	100
24-122-003	3/4 X 14 DC-CC	100
24-124-003	3/4 X 17 DC-CC	100
24-164-003	1 X 17 DC-CC	25

DC Copperclad Flat Electrodes

Specially designed for close tolerance metal removal; excellent for removing weld crowns, repairing or making dies, removing welded dogs and scarfing billets.

Part No.	Description
35-099-003	3/8X5/32X12 DC-CC Flat
35-033-003	5/8X3/16X12 DC-CC Flat



Carbon Rods & Plates

Save time and money by using carbon rods and plates as holding devices when you weld. Welding carbon products eliminate the need for many one-time jigs and fixtures. They are excellent dams or molds for weld deposits. Carbon plates are an excellent backup material when thin sections of metal are to be welded or brazed together or onto thicker sections. In the thin to thick application they are particularly useful since most of the heat is transferred to the thin section. A section of carbon plate placed under the thin section will enable heat to flow more evenly throughout the joint. Carbon plates are very useful in aluminum welding, they prevent sagging of parts during the welding or brazing operation.

Part No.	Description
47-123-000	3/4X12 Rod
47-143-000	7/8X12 Rod
47-164-000	1X17 Rod
47-183-000	1-1/8X12 Rod
47-203-000	1-1/4X12 Rod
47-243-000	1-1/2X12 Rod
47-323-000	2X12 Rod

Part No.	Description
48-043-012	1/4X12X12 Plate
48-063-012	3/8X12X12 Plate
48-083-012	1/2X12X12 Plate
48-123-006	3/4X12X6 Plate
48-123-012	3/4X12X12 Plate
48-163-012	1X12X12 Plate

Angle-Arc Torches

Three torches with the new dimensions of versatility and productivity. All three torches are designed for operator comfort.

- Natural 15° angle in torch
- 360° swivel cable assembly
- Positive grip handle
- Reduced torch and cable weight
- Rugged construction

K2000™ Rated 450 AMPS

The K2000, the smallest member of the Angle-Arc family, is designed for metal removal jobs in such places as repair shops, farms and ranches, body shops and sheet metal shops just to name a few.

Electrodes: 1/8" to 1/4" (3.2 mm to 6.5 mm) round and 3/8" (9.5 mm) flat

Compressed air: 60 psi (4.2 kg/cm²) and 8 cfm (0.23 m³/min)

Weight: 3.6 lbs (1.6 kg) torch and cable only

Part No.	Description
01-046-000	K2000 Torch Only
61-046-000	K2000 Torch & 7' Cable
61-046-001	K2000 Torch & 10' Cable
70-088-107	K2000 7' Cable Only
70-088-110	K2000 10' Cable Only

K3000™ Rated 600 AMPS

The K3000 is the medium-duty torch of the Angle-Arc family. This torch is built for repair and maintenance jobs in areas such as mining, construction, and all types of metal fabrication.

Electrodes: 5/32" to 3/8" (3.97 to 9.5 mm) round and 3/8" (9.5 mm) flat.

Compressed Air: 80 psi (5.6 kg/cm²) and 22 cfm (0.62 m³/min)

Weight: 4.0 lbs (1.8 kg) torch and cable only

Part No.	Description
01-065-000	K3000 Torch Only
61-065-000	K3000 Torch & 7' Cable
61-065-001	K3000 Torch & 10' Cable
70-088-107	K3000 7' Cable Only
70-088-110	K3000 10' Cable Only

K4000™ Rated 1000 AMPS

The K4000 torch is made for heavy-duty metal removal applications such as weld preparations in the pressure vessel shops and shipyards. This torch can be fitted with a heavy duty cable for heavy gouging operations.

Electrodes: 5/32" to 1/2" (3.97 to 12.7 mm) round and 3/8" and 5/8" (9.53 to 15.88 mm) flat.

Compressed air: 80 to 100 psi (5.6 to 7.0 kg/cm²) and 30 to 35 cfm (0.85 to 0.99 m³/min).

Weight: 5.4 lbs (2.4 kg) torch and cable only.

Part No.	Description
01-082-000	K4000 Torch Only
61-082-000	K4000 Torch & 7' Cable
61-082-001	K4000 Torch & 10' Cable
70-084-207	K4000 7' Cable Only
70-084-210	K4000 10' Cable Only

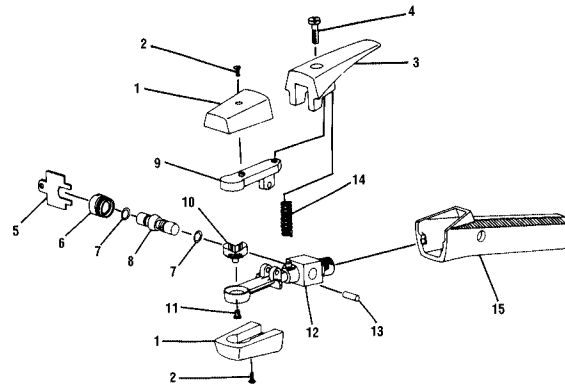

Ref. No.	Description	K2000 Part No.	K3000 Part No.	K4000 Part No.
1	Insulator Assembly	94-433-193	94-433-193	94-433-183
2	Screw	97-142-009	97-142-009	97-142-009
3	Lever and Screw	94-476-080	94-476-080	94-476-066
4	Screw	NLA	NLA	97-192-125
	Valve Bonnet Ass'y. (Items 5 - 8)	94-104-016	94-104-016	94-104-016
5	Wrench	94-960-001	94-960-001	94-960-001
6	Bonnet	94-104-012	94-104-012	94-104-012
	Spool Assembly (Items 7 & 8)	94-801-011	94-801-011	94-801-011
7	O-Rings (2 Required)	94-710-036	94-710-036	94-710-036
8	Spool	94-801-010	94-801-010	94-801-010
9	Upper Arm	94-048-119	94-048-120	94-048-088
10	Head Assembly	94-378-354	94-378-355	94-378-334
11	Screw	97-192-022	97-192-022	97-192-022
12	Body	94-103-233	94-103-232	94-103-206
13	Hinge Pin	94-632-100	94-632-101	94-632-094
14	Spring	94-800-191	94-800-191	94-800-077
15	Handle	94-370-179	94-370-179	94-370-163

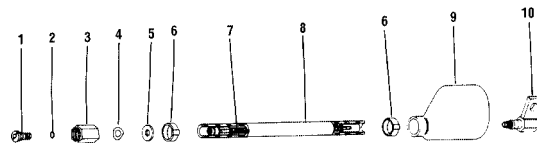

For the K2000/K3000 Cable Part #3 above has male threads

Ref. No.	Description	K2000 Part No.	K3000 Part No.	K4000 Part No.
1	Retainer, Screw	94-695-054	94-695-054	94-695-044
2	"O" Ring	94-710-027	94-710-027	94-710-027
3	Connector	94-170-178	94-170-178	94-565-087
4	Washer, Spring	94-940-104	94-940-104	94-940-104
5	Washer, Flat	94-940-103	94-940-103	94-940-103
6	Clamp (2 Required.)	98-167-010	98-167-010	98-167-010
7	7' Conductor Assembly	96-130-314	96-130-314	96-130-263
7	10' Conductor Assembly	96-130-315	96-130-315	96-130-261
8	7' Replacement Cover	94-171-273	94-171-273	94-171-273
8	10' Replacement Cover	94-171-274	94-171-274	94-171-274
9	Boot, Insulating	94-105-014	94-105-014	94-105-014
10	Connector, Female	94-170-150	94-170-150	94-170-150

K5000 Torch & Cable

Now an angle-arc torch that will accept 5/8" carbon electrodes. This torch will work in places where the user does not want to use the large Tri-Arc foundry torch, but the K4000 isn't quite heavy enough. Will work very well in foundry repair areas to gouge out casting defects in preparations for welding.

Ref. No.	Part No.	Description
1	94-632-105	Hinge Pin
2	94-103-235	Body Assembly
3	94-800-205	Spring Assembly
4	94-476-085	Lever Assembly
5	94-433-202	Upper Insulator Assembly
6	94-048-121	Upper Arm
7	94-378-362	Head Assembly
8	94-433-204	Lower Insulator Assembly
9	94-104-016	Bonnet Assembly
10	94-370-189	Handle Assembly
11	94-013-110	Cable Adapter
12	94-170-150	Female Connector Assembly
13	98-167-010	Clamp (2 Required)
14	94-105-017	Insulating Boot
15	96-130-061	7 ft. Conductor Assembly
16	94-171-004	7 ft. Cable Cover
17	94-170-105	Male Connector
18	94-784-051	Swivel Sleeve
19	94-960-001	Spanner Wrench

Part No.	Description
01-105-000	K-5000 Torch Only
61-105-000	K-5000 Torch & 7 ft. Cable
61-105-001	K-5000 Torch & 10 ft. Cable
70-128-507	7 ft. Swivel Cable
70-128-510	10 ft. Swivel Cable

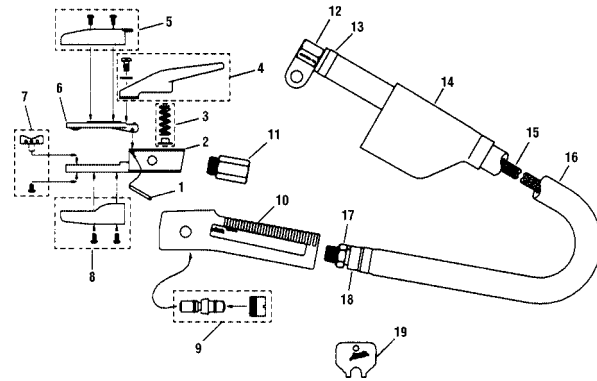

K-3 Torch

Part No.	Description
01-064-000	K-3 Torch Only
61-064-009	K-3 Torch & 7 ft. Cable
61-064-010	K-3 Torch & 10 ft. Cable
70-088-907	7 ft. Swivel Cable
70-088-910	10 ft. Swivel Cable

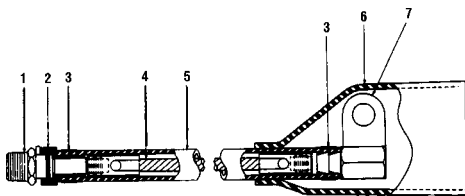
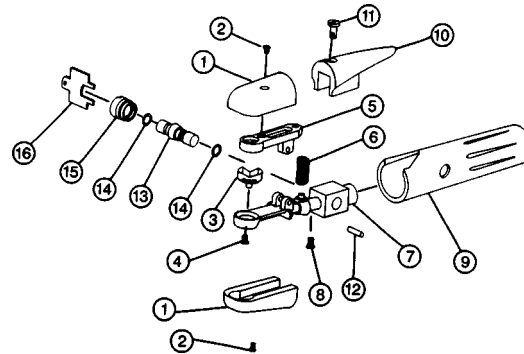

Ref No.	Part No.	Description
1	94-170-149	Male Connector
2	94-784-073	Sleeve
3	98-167-010	Clamp (2 Required)
4	96-130-264	7 ft. Conductor Assembly
4	96-130-265	10 ft. Conductor Assembly
5	94-171-273	7 ft. Cable Cover
5	94-171-274	10 ft. Cable Cover
6	94-105-014	Insulating Boot
7	94-170-150	Female Connector Assembly
	94-170-168	Male Connector Assembly (items 1 - 3)
	94-170-157	Male Connector Assembly (items 1 & 2)

Ref No.	Part No.	Description
1	94-433-118	Insulator Assembly (items 1 & 2)
2	97-142-009	Screw (2 Required)
3	94-378-167	Head Assembly (items 3 & 4)
4	97-192-022	Screw
5	94-048-087	Upper Arm
6	94-800-077	Spring
7	94-103-114	Body Assembly (items 7 & 8)
8	97-192-042	Screw
9	94-370-079	Handle
10	94-476-034	Lever Assembly (items 10 & 11)
11	97-192-154	Screw
12	94-632-094	Hinge Pin
	94-104-016	Valve Bonnet Assembly (items 13-16)
13	94-801-011	Spool Assembly (items 13 & 14)
14	94-710-036	O-Ring (2 Required)
15	94-104-012	Bonnet
16	94-960-001	Spanner Wrench

Tri-Arc Foundry Torch

Three Torches in One



Tri-Arc Foundry Torch

The Tri-Arc Torch has a heavy-duty all purpose body which accepts your choice of interchangeable heads to remove defects, wash pads and perform general purpose cleaning (see charts below). Maintenance is simpler and a smaller stock of replacement parts is required.

The Tri-Arc Torch is 12-1/2" (31.8 cm) long and weighs only 2.4 lbs (1.09 kg) without the concentric cable. The standard Concentric Cable assembly is 7' (2.13 m) in length. Optional 10' Concentric Cable Assembly is available, along with a water-cooled cable assembly.

Defect Removal Heads

For removal of defects and fin removal application.

Electrode Size Inches	Head Assembly Part No.
3/8", 1/2", 5/8", 3/4"	94-378-298

Padwashing Heads

For padwashing applications only. Heads are fixed on a 35° electrode to work angle.

Electrode Size Inches/mm	Head Assembly Part No.
1/2" (12.70 mm)	94-378-286
5/8" (15.88 mm)	94-378-289
3/4" (19.05 mm)	94-378-283

General Purpose Heads

For removal of defects, fin removal, padwashing and piercing applications.

Electrode Size Inches/mm	Head Assembly Part No.
1/2" (12.70 mm)	94-378-267
5/8" (15.88 mm)	94-378-270
3/4" (19.05 mm)	94-378-273
1" (25.40 mm)	94-378-344



Torch Only	Torch & Cable	Description
02-991-411	62-991-417	Torch without Heads
02-991-412	62-991-418	Defect Removal Torch
02-991-413	62-991-419	1/2" Padwashing Torch
02-991-414	62-991-420	5/8" Padwashing Torch
02-991-415	62-991-421	3/4" Padwashing Torch
02-991-416	62-991-422	1/2" General Purpose Torch
02-991-417	62-991-423	5/8" General Purpose Torch
02-991-418	62-991-424	3/4" General Purpose Torch
02-991-424	62-991-434	1" General Purpose Torch

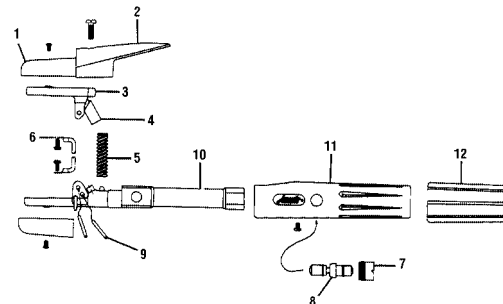

Ref No.	Part No.	Description
1	94-433-118	Insulator Assembly
	97-142-009	Screw (2 Required)
2	94-476-034	Lever Assembly
3	94-048-110	Upper Arm Assembly
4	94-893-183	Air Tube
5	94-800-088	Spring
6	96-458-018	Jumper Assembly (2 Required)
7	94-104-012	Bonnet
9	NLA	Hinge Pin (2 Required)
8	94-801-021	Valve Spool Assembly
	94-710-036	O-ring (2 Required)
10	94-103-221	Body
11	94-370-079	Handle
12	94-784-045	Sleeve

Water Cooled Cable Assembly and Concentric Cable Assembly

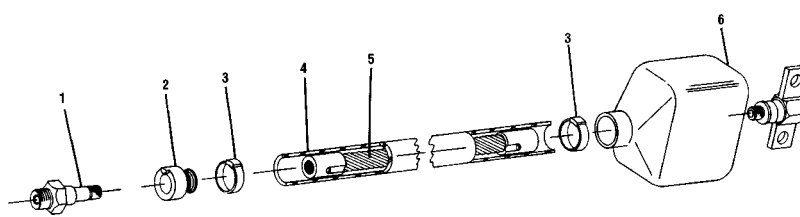

340° Swivel Concentric Cable Assemblies

These concentric cable assemblies supply both power and air to the Tri-Arc Torch. The 340° swivel gives the operator more freedom to maneuver the torch around the workpiece with less fatigue. It also prevents cable twisting and loosening of connections that could cause cable damage. All cables are ruggedly built to withstand the severe operating conditions present in most heavy-duty gouging environments.

Part No. 74-143-607 7 ft. Cable Assembly
Part No. 74-143-610 10 ft. Cable Assembly

Ref No.	Part No.	Description
1	94-170-169	Male Connector Assembly
2	94-784-050	Sleeve, Swivel
3	98-167-012	Clamp (2 Required)
4	94-171-006	7 ft. Cable Cover
	94-171-140	10 ft. Cable Cover
5	96-130-063	7 ft. Conductor Assembly
	96-130-126	10 ft. Conductor Assembly
6	94-105-007	Insulating Boot
7	94-170-095	Female Connector Assembly

Extra Heavy Duty Cable Assembly

Use with the Tri-Arc Torch when current requirements exceeds 1600 amperes. The Cable Assembly was designed to operate at a maximum current setting of 2200 amperes. This cable is only available in a 7 foot length.

Part No. 74-161-907 Extra Heavy Duty Cable

Ref No.	Part No.	Description
1	94-170-176	Male Connector Assembly
2	94-784-078	Sleeve, Swivel
3	98-167-012	Band-It Clamp (2 Required)
4	94-171-284	7 ft. Cable Cover
5	96-130-286	Conductor Assembly
6	94-105-019	Insulating Boot
7	94-170-174	Female Conductor Assembly
NS	94-105-020	Sleeve, Boot

Water Cooled Cable Assembly

The water cooled cable was designed for heavy-duty gouging or continuous use with the Tri-Arc Torch. The cable design allows water to flow around the copper conductor causing a cooling effect. This prevents the conductor from overheating and melting the cable cover. The separate air line is attached to the male connector to supply air to the torch.

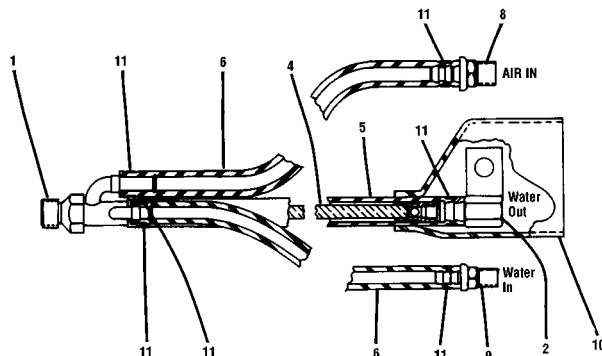

Part No. 74-085-207 7 ft. Water Cooled Assembly
Part No. 74-085-210 10 ft. Water Cooled Assembly

Ref No.	Part No.	Description
1	94-170-171	Male Connector Assembly
2	94-170-150	Female Connector Assembly
3	96-130-309	7 ft. Conductor Assembly
4	94-171-273	7 ft. Cable Cover
	94-171-274	10 ft. Cable Cover
5	NLA	7 ft. Low Pressure Hose
	NLA	10 ft. Low Pressure Hose
6	NLA	Air Hose Fitting
7	NLA	Water Hose Fitting
8	94-105-014	Insulating Boot
9	98-167-010	Clamp (6 Required)
NS	94-105-020	Insulating Sleeve

H-3 Torch



H-3 Torch

Model H-3 is a general purpose Arcair torch that grooves, bevels, cuts, gouges, pierces or flushes away any kind of metal. The Arcair torch saves time, costs less to use, and gives a better finished job than older grinding or chipping methods. Model H-3 is 10-1/8" long and weighs 1-1/2 lbs. (without cable). Standard cable length is 7 ft., with maximum 10 ft. length available. Air and current are easily connected to the Arcair cable.

The torch uses current from a welder, a special Arcair electrode and ordinary compressed air. Both current and air are fed through the torch using the same line, the Arcair Concentric Cable. An arc is produced between the electrode and the metal to be cut or gouged, and the metal instantly melts. At the same time, jets of compressed air come out of the torch head and clean, requiring no further preparation. Air flow is controlled by an on-off valve in the torch handle. The torch head rotates for instant positioning of the electrode to any desired angle. The metal parts of the torch are specially selected for best electrical efficiency and long life. The insulators, lever and handle are made of high impact, heat resistant materials for rugged service and low maintenance.

Electrodes

The H-3 can use 1/8", 5/32", 3/16", 1/4", 5/16" and 3/8" Arcair Copperclad carbon electrodes. These special-blend electrodes assure superior arc stability and greatest economy. Selection of size depends upon the width of the cut or groove desired. DC electrodes are available in all the sizes listed above, while AC electrodes are available in 3/16", 1/4", and 3/8".

Electrical Power

An ordinary welder is normally used as a power source. Care should be taken that the welder is of sufficient size to produce the current required. With DC electrodes, either rectifiers or motor generators are satisfactory. AC electrodes are specially made for use with AC transformer welders. The amperage required to operate this torch depends upon the diameter of the electrode used.

Electrode Size	1/8"	5/32"	1/4"	5/16"	3/8"
Min. Amps DC	30	90	300	350	450
Max. Amps DC	60	150	400	450	600
Min. Amps AC			300		350
Max. Amps AC			400		450

Air Requirements

Compressed air at 80 to 100 psi is used with the H-3. Air may be obtained from the standard shop supply or from any suitable compressor. A 1-1/2 HP compressor is sufficient for moderate use of the H-3, while a 3 HP compressor is recommended for continuous operation.

Part No.	Description
01-062-000	H-3 Torch, without Cable
61-062-016	H-3, complete w/ Swivel Concentric Cable Assembly
61-062-014	H-3, complete w/ Std Concentric Cable Assembly
61-062-015	Torch Assy 10' H3 w/ Concentric Cable
61-062-017	Torch Assy 10' H3 w/ Swivel Cable
70-083-907	Standard Concentric Cable Assembly (7 ft. long)
70-088-907	Swivel Concentric Cable Assembly (7 ft. long)

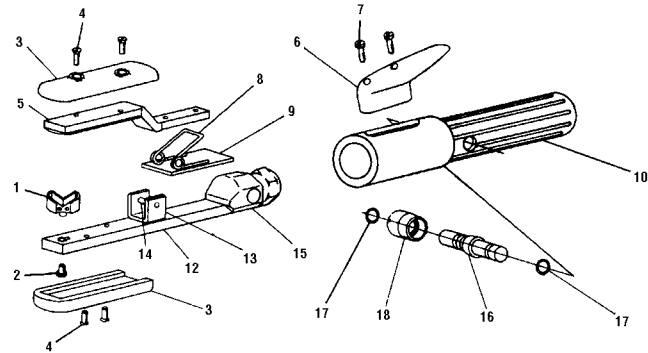

Ref No.	Part No.	Description
1	94-378-007	Head Assembly (includes head & screw)
2	97-192-022	Screw
3	94-433-024	Insulator Assembly (includes 2 insulators, 4 screws)
4	94-142-009	Screw, 4 Required
5	94-048-017	Arm (alloy)
6+7	94-476-003	Lever Assembly (with screws and washers)
7	94-800-013	Spring & Insulators Assembly (includes spring & insulator)
8	94-800-014	Spring
9	94-433-017	Spring Insulator
10	94-370-008	Handle
	94-103-200*	Body Assembly (includes body, hinge, roll pin & valve body)
12	NLA	Body Alloy
13	NLA	Hinge
14	NLA	Roll Pin
15	94-104-016	Valve Bonnet Assembly
16	94-801-010	Spool
17	94-710-036	O-Ring (2 required)
18	94-104-012	Bonnet
	94-960-001	Spanner Wrench (not shown)

* Torches purchased after 9-1-83 use these new part numbers

Part No.	Description
Parts For No. 70-083-907 CABLE	
94-105-014	Insulating boot
94-170-158	Female Cable Connector
94-170-160	Male Cable Connector
94-171-273	Insulating Cable Cover (7 ft.)
96-130-264	Conductor (special wound, 7 ft.)
98-167-010	Clamp (2 required)
Parts For No. 70-088-907 CABLE	
94-105-014	Insulating Boot
94-170-150	Female Cable Connector
94-170-168	Male Connector Assembly
94-171-273	Insulating Cable Cover (7 ft.)
96-130-264	Conductor Assembly (7 ft.)
98-167-010	Clamp (2 required)

Slice Torch and Striker

The SLICE Torch feeds oxygen and electrical power to a specially designed SLICE Exothermic Cutting Rod. You supply oxygen and either a 12-volt battery or a welding power supply. Either way, after turning on the oxygen and touching the carbon steel cutting rod to the grounded workpiece or a striker plate, the cutting rod ignites immediately. The SLICE Torch is sold complete, ready to connect to a welding power supply or battery and an oxygen tank.

Safety features such as a protective hand guard and spark arrestor are built into each SLICE Torch. The torch (Catalog No. 03-003-000) comes with a 10 ft. (3.0 m) power cable and oxygen hose. It is also available with a Cam-lock connector (Catalog No. 03-003-001 and 03-003-006) to make twist lock connections with available packages.

Part No.	Description
03-003-000	SLICE Torch Assembly (#1 Cable)
03-003-001	SLICE Torch Assembly (#6 Cable)
03-003-006	SLICE Torch Assembly (#10 Cable)
72-012-002	Striker Assembly

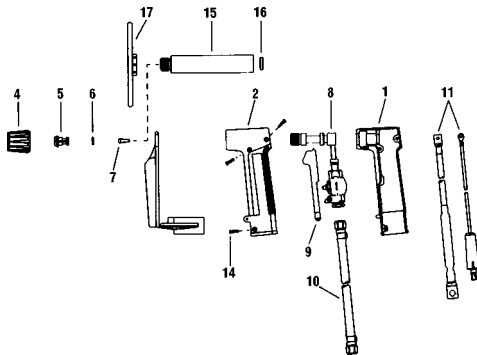

Ref No.	Part No.	Description
1	94-370-166	Handle Assembly, Right Half
2	94-370-167	Handle Assembly, Left Half
3	94-777-109	Shield
4	94-168-022	1/4" Collet Nut Assembly
4	94-168-024	3/8" Collet Nut Assembly
5	94-158-048	1/4" Collet Chuck
5	94-158-045	3/8" Collet Chuck
6	94-940-109	Washer
7	94-305-009	Flashback Arrestor
8	94-378-338	Head Assembly
9	94-476-082	Lever Assembly
10	94-476-082	Oxygen Hose Assembly
11	96-130-279	Cable Assembly - #1
	96-130-276	Cable Assembly - #6
	96-130-319	Cable Assembly - #10
13	NLA	#10-32 X 3/8" Screw
14	NLA	#6-32 X 9/16" Screw (3 Req'd.)
15	94-168-023	Extension - 6"
16	94-940-108	Washer
17	94-777-111	Extension Shield
	94-463-032	3/8" Conversion Kit

The torch for the SLICE Cordless Striker Pack has a 10' oxygen hose, but only has a short cable pigtail for emergency use. The torch is 7.5" (19 cm) long and weighs 7 lbs. (3 kg) with the cables.

An optional SLICE Striker (Catalog No. 72-012-002) may be purchased to provide a convenient surface for igniting the rod with a 12-volt battery instead of a welding power supply.

NOTICE

All SLICE torches come standard with the 1/4" Collet Chuck and Collet Nut. This includes all torches in any SLICE Pack. To utilize the 3/8" rods the user must order the 3/8" rod conversion kit which includes the 3/8" Collet Chuck and Collet Nut.

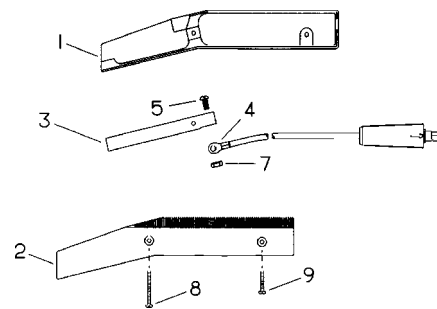

Ref No.	Part No.	Description
1	94-370-168	Handle Assembly (Right Half)
2	94-370-169	Handle Assembly (Left Half)
3	96-070-031	Striker Bar
5	NLA	#10-32 X 3/8" Screw
7	NLA	#10-32 Nut
8	NLA	#6-32 X 1-1/4" Screw
9	NLA	#6-32 X 3/4" Screw

SLICE® Exothermic Cutting Rods

SLICE exothermic cutting rods are designed specifically for use with SLICE cutting systems. Their unique one piece patented construction maintains the balance necessary to sustain the exothermic reaction. Once the oxygen flow is started and the rod is ignited, it will continue to burn without electrical power, as long as oxygen flow is maintained. The following is a list of the SLICE cutting rods available.

Description	Flux coated Part No.	Uncoated Part No.
1/4"x 22" (7x559mm)		
25 pcs.	42-049-002	43-049-002
100 pcs.	42-049-003	43-049-003
1/4"x 44" (7x 1118mm)		
25 pcs.	N/A	43-049-005
3/8"x 18" (10 x 457mm)		
50 pcs.	42-049-005	43-049-007
3/8"x 36" (10 x 914mm)		
25 pcs.	N/A	43-049-009

Slice Packs



Part No. 63-991-026

Slice Utility Pack Parts List

The SLICE Utility Pack permits you to use the exothermic cutting process to cut virtually any metallic, non-metallic or composite material. This package has the basic items needed to do a cutting job packed in a rugged tool box. Just supply oxygen and an ignition source and you are ready to cut. The power cables on the torch and striker assemblies in this pack should be used with a 12-volt battery only. Also included is the collet extension and shield for added protection when piercing.

Part No.	Description
63-991-026	SLICE Utility Pack
03-003-001	Torch Assembly
72-012-002	Striker Assembly
89-250-845	Instruction Manual
94-134-049	Tool Box
94-168-023	Collet Extension Assembly
94-777-111	Extension Shield
96-168-035	Clamp (Red)
96-168-036	Clamp (Black)



Part No. 63-991-021

Industrial Slice Pack

The industrial SLICE pack now gives you the versatility of exothermic cutting and accommodates a larger oxygen cylinder to extend your cutting time. The industrial cart is capable of carrying a 9" diameter cylinder. The industrial SLICE pack includes SLICE torch and striker assemblies with 10' oxygen hose and power cables. Also included is an industrial battery charger for user convenience, 6" collet extension and shield, regulator and a supply of cutting rods with rod storage area. The user supplies their own 12-volt battery to complete the system.

Part No.	Description
63-991-021	SLICE Industrial Pack
92-090-202	Cylinder Cart
NLA	Case
96-156-003	Battery Charger
94-861-003	12" Rubber Tie Down
NLA	U-Bolt
94-698-084	Oxygen Regulator
03-003-001	Torch Assembly
72-012-002	Striker Assembly
NLA	1/4 x 20 Nut (2 Required)
94-394-042	Rod Holder
94-166-079	Clamps (4 Required)
NLA	10-32 X 3/8" Screw (4 Required)
NLA	10-32 Acorn Nut (4 Required)
43-049-002	1/4" Cutting Rods (Qty 25)
94-960-063	Wrench
94-960-064	Wrench
94-168-023	Collet Extension Assembly
94-777-111	Extension Shield
96-168-035	Clamp Assembly (Red)
96-168-036	Clamp Assembly (Black)
89-250-845	Instruction Manual



Part No. 63-991-032

Slice Cordless Striker Pack

The SLICE Cordless Striker Pack is the latest addition to the complete line of exothermic cutting equipment. The SLICE Cordless Striker uses two small lead-acid batteries to supply a current surge sufficient enough to ignite both the 1/4" and 3/8" bare SLICE Cutting Rods.

You no longer need the cables that run from a torch and striker to the battery. All of this has been put in the hand held striker igniter. When it is time to recharge just insert the igniter into one of the receptacles on the recharging unit. The red light will come on indicating the unit is charging. When the green light comes on the igniter is recharged and ready to go. The recharging unit is capable of charging two igniters at a time, in less than four hours.

- Included in Pack:**
- Igniter
 - Recharging Unit
 - Slice Torch
 - Supply of Rods
 - Collet Extension

Part No.	Description
63-991-032	SLICE Pack w/Regulator 120 VAC/60HZ
63-991-033	SLICE Pack w/Regulator 220 VAC/50HZ
94-134-047	Tool Box
03-003-008	SLICE Torch Assembly
72-012-007	Cordless Striker Igniter
96-076-034	Recharging Unit
96-076-030	Igniter and Recharging Unit
94-168-023	Collet Extension Assembly
94-777-111	Collet Extension Shield
NLA	Coupling
43-049-002	1/4 Uncoated Rods (25 Required)
89-250-845	Instruction Manual
72-012-007	Striker Igniter Parts List
94-370-187	Cordless Striker Power Cell
NLA	Head Housing Assembly ¹
NLA	Upper Striker Bar Assembly ¹
NLA	Lower Striker Bar Assembly ¹
NLA	Protective Head Cover

Note 1: Item #2, #4, #5 include mounting screws



Part No. 63-991-003

Slice Pack Battery Unit

The SLICE Battery Unit Pack now comes in a rugged metal tool box. As with the utility pack you get all the basic items needed to do a cutting job such as torch, striker, and rods. Included in the Battery Unit is an ignition source in the form of the 12-volt rechargeable SLICE Battery Box Assembly. You also get the collet extension and shield for piercing.

Part No.	Description
63-991-003	SLICE Battery Pack 120 VAC/60Hz
63-991-007	SLICE Battery Pack 220 VAC/50Hz
43-049-002	1/4" Cutting Rod (Qty. 25)
89-250-857	Literature Pack
96-076-021	Battery Box Assembly
94-134-047	Tool Box
72-012-002	Striker Assembly
03-003-006	Torch Assembly
94-168-023	Collet Extension Assembly
94-777-111	Extension Shield
96-130-297	Charging Cable, 120VAC/60 HZ
96-130-296	Charging Cable, 220VAC/50 HZ
89-250-845	Instruction Manual

Slice Equipment Product Line Parts List

Item	Utility Pack	Battery Pack		Cordless Striker Pack		Industrial Pack
		120 VAC	220 VAC	120 VAC	220 VAC	
Complete Unit	63-991-026	63-991-003	63-991-007	63-991-032	63-991-033	63-991-021
Tool Box, Case, Cart	94-134-049	94-134-047	94-134-047	94-134-047	94-134-047	92-090-202
Torch	03-003-001	03-003-006	03-003-006	03-003-008	03-003-008	03-003-001
Striker	72-012-002	72-012-002	72-012-002	-	-	72-012-002
Cordless Igniter	-	-	-	72-012-007	72-012-007	-
Extension	94-168-023	94-168-023	94-168-023	94-168-023	94-168-023	94-168-023
Shield	94-777-111	94-777-111	94-777-111	94-777-111	94-777-111	94-777-111
Clamp (Red)	96-168-035	-	-	-	-	96-168-035
Clamp (Black)	96-168-036	-	-	-	-	96-168-036
Instruction Manual	89-250-845	89-250-845	89-250-845	89-250-845	89-250-845	89-250-845
Rods, 1/4" x 22"	-	25 uncoated	25 uncoated	25 uncoated	25 uncoated	43-049-002
Battery Box Assy.	-	96-076-021	96-076-021	-	-	-
Charging Cable	-	96-130-297	96-130-296	-	-	-
Battery Charger	-	-	-	96-076-034	96-076-036	96-156-003
O ₂ Regulator Assy.	-	-	-	-	-	94-698-084
Wrench	-	-	-	-	-	94-960-064
Wrench	-	-	-	-	-	94-960-063
O ₂ Cylinder 55 cu/ft	-	-	-	-	-	-
Accessories						
3/8" Conversion Kit	94-463-032	94-463-032	94-463-032	94-463-032	94-463-032	94-463-032
3/8" Collet Chuck	94-158-045	94-158-045	94-158-045	94-158-045	94-158-045	94-158-045
Gloves	94-351-002	94-351-002	94-351-002	94-351-002	94-351-002	94-351-002
Harness Assy.	-	-	-	-	-	-
10' Cable/Hose Ext.	96-130-294	96-130-294	96-130-294	96-130-294	96-130-294	96-130-294
Shade #5 Goggles	94-349-001	94-349-001	94-349-001	94-349-001	94-349-001	94-349-001
O ₂ Regulator Assy.	94-698-084	94-698-084	94-698-084	94-698-084	94-698-084	94-698-084
O ₂ Cylinder 55 cu/ft	-	-	-	-	-	-
Oxygen Auxiliary Case	94-134-046	94-134-046	94-134-046	94-134-046	94-134-046	94-134-046
Exten/Shield Assy	94-287-013	94--87-013	94-287-013	94-287-013	94-287-013	94-287-013
Repair Parts						
Replacement Battery	-	96-076-018	96-076-018	-	-	-
Battery Box Assy.	-	96-076-022	96-076-023	-	-	-

Protex Metalworking Chemicals



Protex Original
53-011-000 1 gal 4/ca.
53-015-000 5 gal
53-018-000 55 gal



Protex Tip Dip
57-021-105 16 oz 12/ca.

Protex Zinc Rich
57-031-002 16 oz 12/ca.

Protex Coolant
57-016-100 1 gal 4/ca.

Protex Alclean
57-021-200 1 qt 12/ca.
57-014-000 1 gal 4/ca.
57-055-000 55 gal



Protex Extra
53-007-500 7 oz Spray 12/ca.
53-024-500 24 oz Spray 12/ca.
53-014-500 1 gal 4/ca.
53-015-500 5 gal
53-018-500 55 gal

Protex Plus
57-021-106 16 oz 12/ca.



Protex Clear
53-014-201 1 gal 4/ca.
53-015-201 5 gal
53-018-201 55 gal

Protex® Original Anti-spatter

The arc stabilizing base material used in Protex Original allows it to withstand temperatures of approximately 1600°F. This product has been used to reduce scale build-up in a heat treating operation. Protex Original can be diluted 1:1 with water before being brushed or sprayed on the surface. One gallon of Protex Original diluted with a gallon of water will cover about 1000 square feet (93 m²). It will dry leaving a durable chalky base to protect the weldment. To remove Protex Original, just brush the surface clean or use a mild detergent and water to remove the residue from the surface. The chloride, fluoride and silicone contents in Protex Original have tested below a level that makes it possible for use in nuclear work. If Protex Original freezes, the natural thickening ingredient used in the material will become useless causing the compound to become thinner. However, this will not effect the compound's ability to reduce spatter. Water based Protex Original is environmentally safe, non-toxic and non-flammable.

Protex Extra

Safe and non-flammable, Protex Extra contains no fluorocarbons or chlorinated solvents. Because the new non-aerosol uses no chemical propellants, it is environmentally safe. It can be used on all types of metals, including aluminum and stainless steel, without corrosion or discoloring in the weld area. Water based Protex Extra is environmentally safe, non-toxic and non-flammable.

Protex Plus

Protex Plus is an aerosol anti-spatter that contains no chlorinated solvents, fluorocarbons or silicones. Fixtures, weldments and tools can also be sprayed allowing spatter to be wiped or brushed away after welding. For users preferring an aerosol product, Protex Plus is good for quick applications. Protex Plus is environmentally safe and non-flammable. The use of an inert gas propellant is less stressful to the environment.

Protex Clear

Because of its latex base, Protex Clear will provide a barrier that works for months to shield work surfaces and fixtures from oxides and rust. The clear coat allows any identification marks to be easily read and protected from environmental damage. Apply Protex Clear using a brush or standard paint sprayer, perform the work, then remove if necessary. Because of Protex Clear's latex base, total removal must be done using an industrial grade cleaner or ammonia base solution. Protex Clear is environmentally safe and non-flammable.

Protex Alclean

Brush or spray Protex Alclean on the work surface or use the solution as a dip bath to clean small parts. Once parts are clean, just rinse away any remaining Alclean with water. Do not use Protex Alclean on glass, galvanized, anodized, cadmium coated or painted surfaces. This compound may discolor 2000 Series aluminum alloy.

Protex Tip-Dip

When the nozzle of the MIG gun is warm, simply dip into the gel. This will set up a film on the parts to provide hours of protection. Protex Tip-Dip is non-toxic and non-flammable. Although Protex Tip-Dip is non-flammable, contact with heat sources over 1000°F (538°C) may cause a temporary flame-up. Therefore allow MIG gun nozzle to cool below the red hot state before dipping in Protex Tip-Dip.

Underwater Products

Sea-Jet Cutting Electrodes

Sea-Cut I electrodes are a patented tubular steel design used for oxygen-arc cutting. The outside diameter is 5/16" (8mm) with a bore hole of .113 (3mm) diameter. These electrodes are coated with a waterproof insulating material. They are **NOT FLUX COATED**.



Part No.	Description
14-050-124	Sea Torch w/5/16" Collet
42-024-002	Electrode Sea Weld 1/8" 150/min
42-059-007	Electrode 5/16" Sea-Cut 150/min
42-066-006	Electrode 3/8" Sea Jet 50/min
42-075-005	Electrode Sea-Dragon 3/8" 50/min
94-158-043	Collet 5/16"
94-158-044	Collet 3/16"
94-158-047	Collet 1/8"
94-168-018	Collet Assembly