

Air-Acetylene Equipment - "Screw-In Style"

TARGET® Kits and Tips



These kits include our most economically priced air-acetylene tips. Their design makes them inexpensive while still producing excellent flame characteristics.

Part No. KA-1H

Kits include UL listed regulator and hose.

Kit No.	Tip No.	Reg. FTG
KA-1H	BA-3	"B" Cylinder
KA-2H	BA-3	"MC" Cylinder
KA-31	BA-2, BA-3, BA-4	"B" Cylinder
KA-32	BA-2, BA-3, BA-4	"MC" Cylinder
KA-37H*	BA-4	"B" Cylinder
KA-38H*	BA-4	"MC" Cylinder

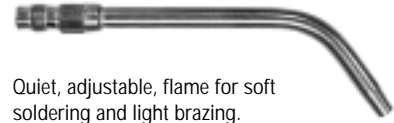

Quiet, adjustable, flame for soft soldering and light brazing.

Tip No.	Flame Diameter	Soft Solder
BA-1	1/16"	1/16"-1/8"
BA-2	1/8"	1/8"-1/4"
BA-3	3/16"	1/4"-1/2"
BA-4	1/4"	1/2"-1"
BA-5	5/16"	1"-1 1/2"
BA-6	7/16"	2"-4"

Contents: HA3-12 hose, regulator, AA-1 handle, MP-1 lighter and MA-2 wrench.

*These kits DO NOT include lighter or key wrench.

TARGET® Kits and Tips



Kits feature the screw-in style Target Tips which are known for their durability and very high flame temperature at an economical price.

Part No. KA-3H

Kits include UL listed regulator and hose.

Kit No.	Tip No.	Reg. FTG
KA-3H	BA-10A	"B" Cylinder
KA-4H	BA-10A	"MC" Cylinder
KA-7H	BA-9A, BA-12A	"B" Cylinder
KA-8H	BA-9A, BA-12A	"MC" Cylinder



Very hot adjustable flame for fast soldering or brazing.

Tip No.	Flame Diameter	Soft Solder
BA-9A	1/4"	Up to 1"
BA-10A	3/8"	Up to 2 1/2"
BA-12A	1/2"	Up to 4"

Contents: HA3-12 hose, regulator and AA-1 handle, MP-1 lighter and MA-2 wrench.

ZIP-TIP® Kits and Tips



The Zip-Tips included in these kits provide medium flame temperature with a large pencil point style flame.

Part No. KA-71H

Kits include UL listed regulator and hose.

Kit No.	Tip No.	Reg. FTG
KA-71H	BA-20	"B" Cylinder
KA-72H	BA-20	"MC" Cylinder
KA-81H	BA-20, BA-25	"B" Cylinder
KA-82H	BA-20, BA-25	"MC" Cylinder



Adjustable flame can be used to braze and solder.

Tip No.	Flame Diameter	Soft Solder
BA-20	7/32"	1/4" to 1"
BA-25	1/4"	1" to 3 1/4"
BA-30	7/16"	3" to 6"

Contents: HA3-12 hose, regulator and AA-1 handle.

Air-Acetylene Equipment - "Snap -In Style"

TARGET® Kits and Tips



Kits feature the very hot, compact, adjustable Target Tips for professional soldering and brazing applications. Kits also include a quick disconnect handle, UL listed regulator, hose and accessories.

Part No. KX-3B

Choose from a wide selection of kits below.



TARGET® Tips

- ▲ Very hot turbine flame.
- ▲ Adjustable tips that don't burn up.
- ▲ Unique mixer design cuts brazing time by 30% over conventional tips.
- ▲ Tips have a filter and removeable orifice.
- ▲ Interchangeable with other quick disconnect style tips.
- ▲ Made of heavy stainless steel and brass.
- ▲ Tips fit GG-4 handle.

Kit No.	Tip No.	Regulator FTG
KX-3B	GA-3, GA-11	"B" Cylinder
KX-4B	GA-5, GA-14	"B" Cylinder
KX-5B	GA-5	"B" Cylinder
KX-5MC	GA-5	"MC" Cylinder
KX-6MC	GA-3, GA-8	"MC" Cylinder
KX-7B	GA-8	"B" Cylinder

Tip No.	Flame Diameter	Soft Solder	Silver Solder
GA-3	1/4"	1/4"-1"	1/8"-1/2"
GA-5	5/16"	3/4"-1 1/2"	1/4"-3/4"
GA-8	3/8"	1"-2 1/2"	1/2"-1"
GA-11	7/16"	1 1/2"-3 1/4"	3/4"-1 1/2"
GA-14	1/2"	2"-4"	1"-2"
GA-32	3/4"	3"-6"	1 1/2"-4"

Kit contents: HA3-12 (12' Hose), GG-4 Torch, Tip(s) and Regulator.

EZE-LITE™ Instant Ignition Kitts and Tips



Kits feature EZE-Lite push button spark ignition tips with a swirl action flame. Also featured is the quick disconnect handle, durable regulator and hose.

Part No. KX-10B

Kits are prematched to different tip and tank sizes.



EZE-LITE™ Tips

- ▲ Innovative spark igniting turbine flame tip ignites with the push of a button.
- ▲ Interchangeable with other quick disconnect style tips.
- ▲ Removeable/cleanable orifice.
- ▲ Tips fit GG-4 handle.

Kit No.	Tip No.	Regulator FTG
KX-10B	GA-36	"B" Cylinder
KX-10MC	GA-36	"MC" Cylinder
KX-15B	GA-38	"B" Cylinder
KX-15MC	GA-38	"MC" Cylinder

Tip No.	Flame Diameter	Soft Solder	Silver Solder
GA-36	1/4"	Up to 2"	Up to 1"
GA-38	3/8"	Up to 4"	Up to 2"
GA-40	1/2"	Up to 6"	Up to 4"

Air-Acetylene Equipment

Torch Handles

ACET-O-LITE® (screw-in)

AA-1 has the adjustment valve in the front for single hand operation, the AA-3 has the valve in the rear for fingertip control. Needle valve design enables very fine flame adjustments. *These torches will keep your tips burning efficiently in drafts, winds, and adverse conditions.* Both torches are made with quality brass, have very durable handles and use standard 3/8-24 LH "A" size hose fittings.

Part No. AA-1



Part No. AA-3



Goss Acet-O-Lite torches work with all "BA" style tips

TARGET TORCH® (snap-in)

This handle has a quick disconnect fitting to rapidly change tips. Comfortable grooved handle is made of very durable materials. Uses 3/8-24 LH "A" hose fittings.

Part No. GG-4



The Target Torch handle will work with all "GA" style tips

Acetylene Regulators

These UL LISTED regulators, manufactured of solid brass, are made for rugged use. *They have a specially designed conical seat and a neoprene diaphragm.* The inlets have filters to prevent dirt from entering the regulator.

EA-1G B cyl. connection
"A" Hose fitting 3/8-24 L.H.

EA-2G MC cyl. connection
"A" Hose fitting 3/8-24 L.H.

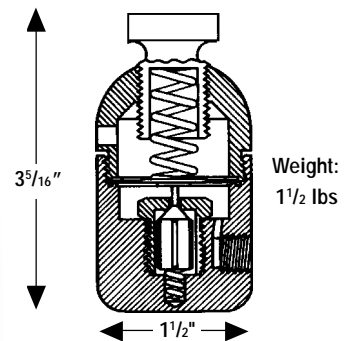

Acetylene Hose

ACET-O-LITE®

Hose assemblies are made of quality 7/16" OD x 3/16" ID single ply fabric reinforced Grade R hose. It has a 200 PSI working pressure.



- HA3-6** Hose 6 feet long with "A" connections
- HA3-12** Hose 12 feet long with "A" connections
- HA3-25** Hose 25 feet long with "A" connections

Soldering Irons

These irons are ideal for soldering light gauge sheet metal. The DA-1 has a pyramid copper point and the DA-2 has a chisel copper point. Use with either model AA-1 or AA-3 torch handle.



Part No. DA-1



Part No. DA-2

Acetylene Stands

Heavy duty steel stand with hose rack, support base and handle.

Part No. C-800
for MC size acetylene cylinders

Part No. C-850
for B size

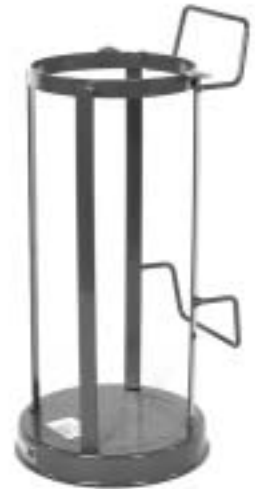

Halide Leak Detector

A sensitive leak detector for refrigerant gas. The flame, when adjusted, will quickly change color as the 24 inch search hose passes a leak.

For use with models AA-1 or AA-3 torches.



Part No. DA-8

Flame Shield

Deflects heat when soldering copper tubing.



MP-14
Use with BA-3, BA-4, BA-10A and GA-8 Tips.

MP-15
Use with BA-5, BA-6, BA-12A and GA-14 Tips.

Screw-Adaptor

Part No. BRS-770



Adapts snap-in tips to torch handles with screw-in design.

Torch Adaptor

Part No. BRS-700



Converts TC-23WA oxy/fuel torch to air/fuel tips.

Torch Stand

Supports torch to eliminate relighting and prevents the hot tip from touching the work surface. Fits EX style extensions.

Part No. MP-10



Quicky-Adaptor

Part No. BRS-665



Adapts the Goss wide variety of Pencil, Brush or Target® Tips to torch handles with snap-in design.

Air-Propane Equipment - "Screw-in Style"

Propane Kits with Pencil and Brush Tips



Kits contain a complete selection of high quality soldering and heating equipment.

Part No. KP-102

Kit No.	Tip No.
KP-102	BP-2
KP-105	BP-5

Kits include: AP-1 handle, EP-70G regulator, MP-1 lighter and HEF-10 hose and tip listed.



▲ Quiet, Adjustable Flame

Tip No.	Flame	Diameter	Soft Solder	BTU's @ 40 psi
BP-1	Pencil	5/8"	To 1/2"	6,000
BP-2	Pencil	1"	To 1 1/2"	11,000
BP-3	Brush	7/8"	To 2"	14,000
BP-4	Brush	1 1/8"	To 3"	43,000
BP-5	Brush	1 3/4"	To 4"	57,000
BP-6	Brush	2 1/8"	To 5"	300,000

TARGET® Propane Kits and Tips



Kits feature the very hot, compact Target Tips. Kits also include a handle, UL listed regulator and accessories.

Part No. KP-115

Kit No.	Tip No.
KP-115	BP-15PM
KP-117	BP-17PM

Kits include: AP-1 handle, EP-70G regulator, MP-1 lighter and HEF-10 hose and tip listed.



▲ Hot Compact Flame

▲ Economical Screw-In Design

Tip No.	Flame Diameter	Soft Solder	Silver Solder
BP-13PM	7/16"	To 1"	1/2"
BP-15PM	1/2"	To 1 1/2"	5/8"
BP-17PM	3/4"	To 4"	2"

EZE-Lite™ Instant Ignition Kits and Tips

Same as KP-115 except includes the BP-15PML ignitor tip.

Kit No.	Tip No.
KP-115L	BP-15PML

Tip No.	Flame Diameter	Soft Solder	Silver Solder
BP-15PML	1/2"	To 1 1/2"	5/8"

Torch Handle

Comfortable handle design reduces operator fatigue. Up front valve offers single handed operation.

This handle accepts all screw-in tips shown on this page.
Uses HEF hose. 9/16"-L.H., "B" hose fitting.

Part No. AP-1



TARGET® Propane Kits and Tips



Kits feature the very hot, compact Target Tips for professional soldering and brazing applications. Kits also include a quick disconnect handle, UL listed regulator and accessories. Choose from a wide selection of kits.

Part No. KLP-4

Kits Include: GH-4 handle, HEF-12 hose, EP-70G regulator and torch tip(s).

Kit No.	Tip No.
KLP-2	GT-3, GT-5
KLP-4	GT-4

- ▲ Hot turbine flame.
- ▲ Unique mixer design cuts brazing time by 30% over conventional tips.
- ▲ Tips have a filter and removeable orifice.
- ▲ Interchangeable with other quick disconnect style tips.
- ▲ Made of heavy stainless steel and brass.
- ▲ Tips fit GH-4 handle.



Tip No.	Flame Diameter	Soft Solder	Silver Solder
GT-3	7/16"	Up to 1"	Up to 1/2"
GT-4	1/2"	Up to 1 1/2"	Up to 5/8"
GT-5	3/4"	Up to 4"	Up to 2 1/2"

EZE-Lite™ Instant Ignition Kits and Tips



Kits feature propane EZE-Lite push button spark ignition tips with a swirl action flame.

Part No. KLP-4L

Kits Include: GH-4 handle, HEF-12 hose, EP-70G regulator and tip.

Kit No.	Tip No.
KLP-4L	GT-4L

- ▲ Innovative spark igniting turbine flame tip ignites with the push of a button.
- ▲ Interchangeable with other quick disconnect style tips.
- ▲ Removeable/cleanable orifice.
- ▲ 100% flame tested.
- ▲ Tips fit GH-4 handle.



Tip No.	Flame Diameter	Soft Solder	Silver Solder
GT-4L	1/2"	Up to 1 1/2"	Up to 5/8"

Torch Handle

Ribbed handle provides positive grip. Precision machined needle valve allows greater range of flame control. Utilizes quick disconnect for fast tip change over.

For use with tips shown above.

Uses HEF hose.
3/16"-L.H., "B" hose fitting

Part No. GH-4



Air-Propane/MAPP® Equipment

Heavy Duty Hand Torches for Disposable Cylinders

GP-360R Features:

- ▲ Hot turbine flame.
- ▲ Heavy duty brass regulator.
- ▲ Used with either propane or Mapp® gas.
- ▲ Stainless steel tip ends.



360° Swivel Tip
Rotates to any position for hard to reach areas.

Cylinder not included

GP-360 Torch Accessories

EP-20BR

Regulator for disposable cylinder with (B) hose outlet connection.



Part No. EP-20BR

EP-20R

Regulator body for the GP-360 Series torch.

BP-20TER

Stainless steel tip for GP-360R torch.



Part No. BP-20TER

BRS-480

Orifice for GP-360R Series torches.

"Sidewinder Kits"



Features:

- ▲ Has 12 ft. Of hose.
- ▲ Utilizes goss target tips on both model of kits.
- ▲ Spare cylinder storage.
- ▲ Hose hanger for sidewinder storage.
- ▲ Available with piezoelectric ignitor tip.

Cylinders not included

KP-26 Kit, C-500 Stand only



Kits:

KP-26: Snap-In Style Handle

Contents: EP-20BR Regulator, GH-4 Handle, GT-4 Target Tip, MP-1 Lighter, HP3-12 Hose, C-500 Stand.

KP-26L: Snap-In Handle with Ignitor Tip

Contents: Same as KP-26 except includes GT-4L Ignitor Tip.

KP-27: Screw-In Style Handle

Contents: EP-20BR Regulator, AP-1 Handle, BP-15PM Target Tip, MP-1 Lighter, HP3-12 Hose, C-500 Stand.

KP-27L: Screw-In Handle with Ignitor Tip

Contents: Same as KP-27 except includes BP-15PML Ignitor Tip.

Hand Torches for Disposable Cylinders

This torch is designed for durability at an economical price. It has the quality features that you would expect in a Goss torch.

Features:

- ▲ Used only with propane gas.
- ▲ Economical and practical for light duty jobs.
- ▲ Flame control valve gives precise adjustments.
- ▲ Solid brass construction.
- ▲ More durable than most torches of this type.
- ▲ No plastic or anodized aluminum parts.

Part No. GP-6
Economy Torch
Propane Only



From Goss, "the innovators of the hand torch," comes the dependable GP-9 Torch.

Made of the finest brass materials, this torch has soft soldering capabilities and is a popular choice for plumbing, heating, electrical and many other uses.

Features:

- ▲ A tip that can be used with propane or Mapp® gas without changing the orifice.
- ▲ Easily adjusted to three different flames without changing tip ends.
- ▲ Attractively packaged for pegboard display.
- ▲ Torch can be used in any position after tip end has preheated.

Cylinder not included

Part No. GP-9
Heavy Duty Torch
Propane / MAPP®

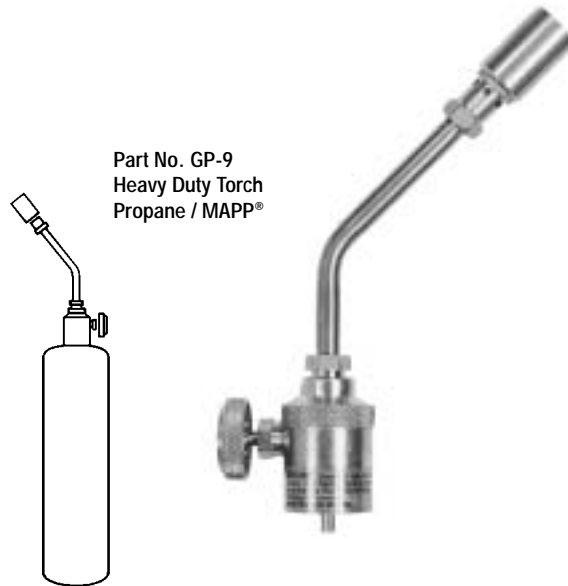

Leak Detector

Use with disposable propane or MAPP® gas cylinders. The flame, when adjusted to heat the reactor plate, quickly changes color as the search hose passes a leak of refrigerant gas.

Features:

- ▲ 24" search hose.
- ▲ Blackened shell to easily observe flame color.
- ▲ Replacement parts available.

Cylinder not included



Part No. GP-18

Air-Propane Equipment



Heavy duty kits designed for rugged use anywhere large volumes of heat are required. KP-201MA Shown.

Kits

KP-201: Includes AP-25 torch, EP-80G regulator, HEF-10 hose, and MP-1 lighter.

KP-201M: Same as above with BP-66 piezoelectric ignitor tip.

KP-201A: Includes AP-25 torch, IP-2 flow adaptor, HEF-10 hose, and MP-1 lighter.

KP-201MA: Same as above with BP-66 piezoelectric ignitor tip.

Regulators and flow adapters are Listed

CAUTION

This equipment is an unvented device not designed for use indoors and **MUST NOT** be used in an enclosed area. **DO NOT** leave equipment operating unattended.

Follow operating instructions included with this equipment. Use in accordance with all Federal, State and local regulations.

ProFlame® Torches

This equipment can be used for weed burning, drying, heating, melting and other applications requiring large volumes of outdoor heat. Each uses vapor propane fuel and has a durable handle with rear on/off control valve.

They are used by contractors and farmers as well as road, railway and industrial maintenance crews.

Torches With Steel Burner

Part No. AP-6



Has two grips for easy handling

Part No. AP-10A



Propane or Natural Gas

Part No. AP-25

AP-25M Includes BP-66 Piezoelectric Ignitor Tip

AP-25N For Natural Gas



Torch With Cast Iron Burner

Part No. AP-14



Blue-Jet Torch

Torch With Compressed Air Nozzle

Part No. AP-27



Propane burner with a separate air nozzle that blows debris and moisture from area to be repaired. Ideal for road work where cracks have to be cleaned out and dried.

Torch contains two separate valves to control heat and compressed air.

Clean and dry in one easy step.

Torch No.	Total Length (inches)	Weight (lbs.)	Approx. BTUs MAX	Approx. Gas Usage at 70 PSI (lb./hr.)	Tip	Tip Diameter (inches)
AP-6/AP-10A	38 1/2	3 1/4	500,000	20	BP-8TE	3
AP-14	27	5 1/2	500,000	20	BP-10	2 3/8
AP-25	31	1 3/4	500,000	20	BP-6TE	2 1/8
AP-27	38	7	500,000	20	BP-6TE	2 1/8

READY-FLAME Combination Torches For Roofing, Heating and Heat Shrinking

Part No. AP-54

Designed for continuous or intermittent use. At the squeeze of a lever, operator can go from pilot flame to full-brush flame as needed. Has adjustable pilot valve.



Part No. AP-54

Part No. AP-99

Has same quality construction and versatile features as all Ready-Flame Torches but without pilot valve and lever flame control.







Match tips and extensions below for your needs.



Part No. AP-99

Tip Ends for Extensions

Engineered to provide a variety of heat and flame characteristics when combined with the handles and extensions on this page.

Tip	Diameter (inches)	Approx. BTU's at 40 PSI	Type Flame
BP-2TE 	1	11,000	Pencil*
BP-3TE 	7/8	14,000	Brush*
BP-4TE 	1-1/8	43,000	Brush*
BP-5TE 	1-3/8	57,000	Brush*
BP-6TE 	2-1/8	300,000	Brush**
BP-66 	2-1/8	300,000	Brush**
BP-8TE 	3	300,000	Brush**

* For propane or Mapp® gas.
** For propane or natural gas.

Brass Extensions for Torches



Screws onto AP-54 or AP-99.

Extension	Description (inches)
EX-4B	4" Bent
EX-12B	12" Bent
EX-12S	12" Straight
EX-18B	18" Bent
EX-18S	18" Straight
EX-18DB	18" Double Head Bent
EX-18DS	18" Double Head Straight
EX-30B	30" Bent

Heat Shrink Tip	
Screws onto both AP-54 or AP-99 torch. This tip has a short, wide soft flame used for heat shrinking plastics.	BP-75 (Soft Flame) 

Assembled Steel Extension Torches

Used for applications requiring large volumes of heat.

Each has a steel extension and an adjustable pilot valve.

At the squeeze of a lever, operator can go from pilot flame to full-brush flame.

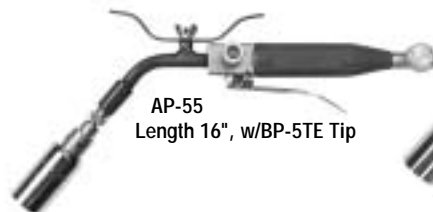

AP-55
Length 16", w/BP-5TE Tip

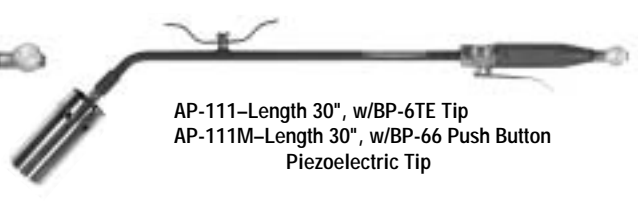

AP-111—Length 30", w/BP-6TE Tip
AP-111M—Length 30", w/BP-66 Push Button Piezoelectric Tip

Steel Extension Kits

Kit No. KP-155-H
Contents: AP-55 Torch, MP-1 Lighter, HEF-20 Hose, EP-80G Regulator

Kit No. KP-318M-H
Contents: AP-111M Piezo Ignition Torch, HEF-25 Hose, EP-80G Regulator

Air-Propane Equipment

Outdoor Furnaces

Part No. FP-540



Used For:

- ▲ Lead Melting
- ▲ Outdoor Cooker ▲ Clam Bakes
- ▲ Corn Roast ▲ Deep Frying
- ▲ Use Furnaces with EP-70G or EP-80G Regulator



Part No. FP-5000

Floor Furnace*

A well-constructed lead melting furnace with brush flame burner.

BTUs	Approx. 43,200
Gas Usage	Approx. 2 lb./hr.
Height	8 in.
Weight	8 lb.
Diameter	8 1/2 in.

* For propane only

CAUTION

This equipment is an unvented device not designed for use indoors and **MUST NOT** be used in an enclosed area.

DO NOT leave equipment operating unattended.

Follow operating instructions included with this equipment.

Use in accordance with all Federal, State and local regulations.

Utility Furnace*

A lead melting furnace with soft flame burner used by utility companies.

BTUs	Approx. 43,200
Gas Usage	Approx. 2 lb./hr.
Height	10 in.
Weight	9 3/4 lb.
Diameter	8 1/2 in.

Wind Shields

(For All Furnaces Above)



Part No. FP-S1
Straight wind shield.
Diameter: 7 5/8 in.



Part No. FP-S2
Spun wind shield.
Top Diameter: 9 1/8 in.

Lead Pot and Ladle

Part No. MP-3

7 in. diameter cast iron lead pot.
Holds 50 lb. of lead.



Part No. MP-5

3 in. diameter
cast iron ladle.



Soldering Iron

FEATURES:

- ▲ Adjustable Pencil Point Flame
- ▲ Durable Steel Construction
- ▲ Replaceable Copper Ends
- ▲ Removeable Stand

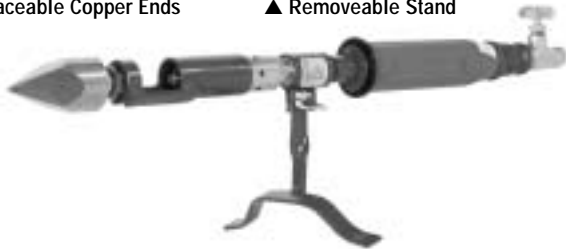

DP-9	Complete soldering iron with small pyramid copper
DP-9A	Small pyramid copper only — 3/4 inch diameter
DP-10	Complete soldering iron with small chisel copper
DP-10A	Small chisel copper only — 3/4 inch diameter
DP-11	Complete soldering iron with large pyramid copper
DP-11A	Large pyramid copper only — 1 1/4 inch diameter
DP-12	Complete soldering iron with large chisel copper
DP-12A	Large chisel copper only — 1 1/4 inch diameter



Kit KP-25

Kit includes:

DP-11	Soldering Iron
DP-9A	Copper Tip
HEF-10	LP Hose
EP-80G	Regulator
MP-1	Lighter

Hose

Vapor Propane Gas Hose

Quality flexible hose utilizes the standard 9/16-18 LH hose fittings.

Working pressure: 350 PSI.

Outside diameter: 9/16"

Inside diameter: 1/4"



Hose No.	Length (ft.)
HEF- 6	6
HEF-10	10
HEF-12	12
HEF-20	20
HEF-35	35
HEF-50	50

Not for use with Natural Gas

Vapor Propane / MAPP® / Natural Gas Hose

Quality flexible hose for use with multiple gases.

9/16-18 LH hose fittings.



Working pressure: 200 PSI.

Outside diameter: 7/16"

Inside diameter: 3/16"

Hose No.	Length (ft.)
HP3-12	12

Grade "T" Hose

Propane Regulators

High Pressure

Use only with vapor withdrawal cylinders.

Part No. EP-70G



All brass regulators used with propane torches and furnaces.

Adjustable pressure from 5 to 60 PSI. UL Listed with POL inlet spud and nut, 1/4" NPT openings, and 9/16 - 18 LH hose outlet.

EP-70G

Has 0 to 60 PSI outlet pressure gauge for propane gas.

EP-80G

Has 0 to 70 PSI outlet pressure without gauge for propane gas.

XP-234

Regulator with dust cap and heavy duty inlet nut for propane gas.

Low Pressure

For vapor withdrawal cylinders.



This regulator has approx. 6-7 oz. or 11" water column outlet pressure and is for applications requiring low gas pressure. UL LISTED with 1/4" NPT inlet and 3/8" NPT outlet. **Do not use with any Goss LP torch or furnace equipment.**

- EP-60 - 0 Body only, no fittings.
- EP-60 - 1 POL inlet, 3/8" flare outlet.
- EP-60 - 2 POL inlet, 1/4" flare outlet.
- EP-60 - 3 POL inlet, LH hose outlet.
- EP-60 - 4 T-Block inlet, 3/8" flare outlet.
- EP-60 - 5 POL inlet less outlet.

Low Pressure with OPD Tank Connection

For vapor withdrawal cylinders.



Same features as the EP-60 regulators except it utilizes an OPD cylinder connection.

- EP-90 - 0 Body only, no fittings.
- EP-90 - 1 Type 1 inlet, 3/8" flare outlet.
- EP-90 - 2 Type 1 inlet, 1/4" flare outlet.
- EP-90 - 3 Type 1 inlet, LH hose outlet.
- EP-90 - 5 Type 1 inlet, less outlet.

Parts List

EA-G & EP-G Regulators

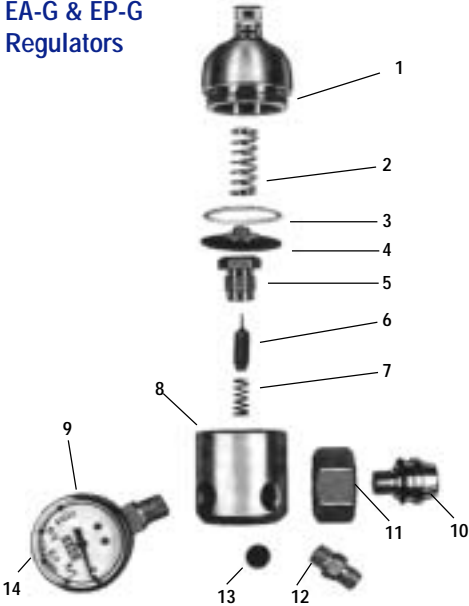

AP Torches

AP-50 / AP-54P

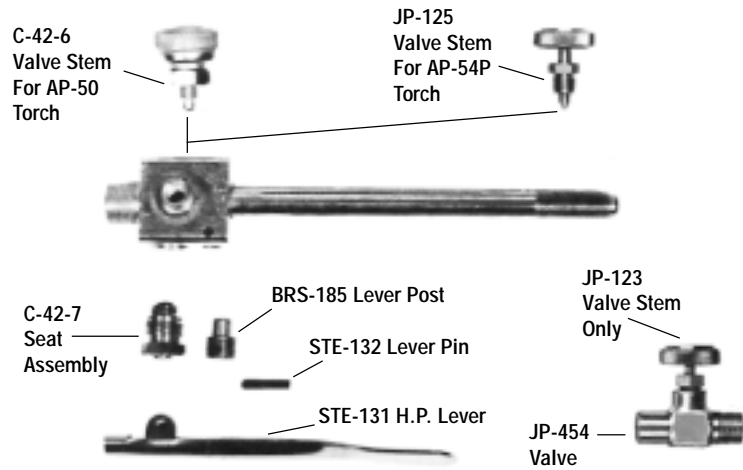

Regulator	EA-1G Acet.	EA-2G Acet.	EA-3G Acet.	EA-4G Acet.	EP-7G		EP-8G	
					EP-70G	EP-80G		
1. Bonnet Assembly	BRS-688	BRS-688	BRS-688	BRS-688	BRS-688	BRS-688	BRS-688	BRS-688
2. Range Spring	STE-143	STE-143	STE-143	STE-143	STE-286	STE-144	STE-144	STE-144
3. Diaphragm Gasket	PLA-104	PLA-104	PLA-104	PLA-104	PLA-104	PLA-104	PLA-104	PLA-104
4. Diaphragm Assembly	RUB-116	RUB-116	RUB-116	RUB-116	RUB-116	RUB-116	RUB-116	RUB-116
5. Seat Nut	BRS-282	BRS-282	BRS-282	BRS-282	BRS-282	BRS-282	BRS-282	BRS-282
6. Seat	BRS-411	BRS-411	BRS-411	BRS-411	BRS-411	BRS-411	BRS-411	BRS-411
7. Seat Spring	STE-170	STE-170	STE-170	STE-170	STE-170	STE-170	STE-170	STE-170
8. Body	BRS-273A	BRS-273	BRS-273A	BRS-273	BRS-194 MP-700	BRS-194L MP-673	BRS-682 BRS-682L	BRS-682 BRS-682L
9. Gauge	MA-80-16	MA-80-16	None Used	None Used	None Used	None Used	None Used	None Used
10. Inlet Stem	BRS-359	BRS-361	BRS-359	BRS-361	BRS-343	BRS-343	BRS-343	BRS-343
11. Inlet Nut	BRS-357	BRS-360	BRS-357	BRS-360	BRS-355	BRS-355	BRS-355	BRS-355
12. Outlets	BRS-382	BRS-382	BRS-382	BRS-382	BRS-328	BRS-328	BRS-328	BRS-328
13. Filter	STE-172	STE-172	STE-172	STE-172	STE-172	BRS-331	STE-172	BRS-331
14. Gauge Crystal			GC-3		STE-322	STE-322	STE-172	STE-322
							GC-7	GC-7

Tip Orifices

Tip	Orifice	Tip	Orifice	Tip	Orifice
BA-1	BRS-140	BP-2TE	BRS-123	GA-8	BRS-126
BA-2	BRS-142	BP-3TE	BRS-126	GA-11	BRS-881
BA-3	BRS-147	BP-4TE	BRS-128	GA-14	BRS-526
BA-4	BRS-150	BP-5TE	BRS-129	GA-32	BRS-517
BA-5	BRS-153	BP-6TE	BRS-520L	GA-36	BRS-453
BA-6	BRS-156	BP-8TE	BRS-520L	GA-38	BRS-454
BA-9A	BRS-464	BP-13PM	BRS-303	GA-40	BRS-455
BA-10A	BRS-126	BP-15PM	BRS-464	GA-3	BRS-303
BA-12A	BRS-526	BP-17PM	BRS-881	GT-4	BRS-123
BA-20	BRS-726	BP-66	BRS-732	GT-4L	BRS-123
BA-25	BRS-727	GA-3	BRS-464	GT-5	BRS-881
BA-30	BRS-728	GA-5	BRS-123	GP-360R, GP-360L	BRS-480

AA Torches

Part No. AA-1

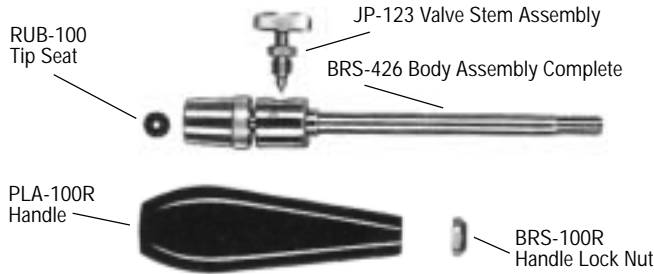

AP Torches

Part No. AP-1

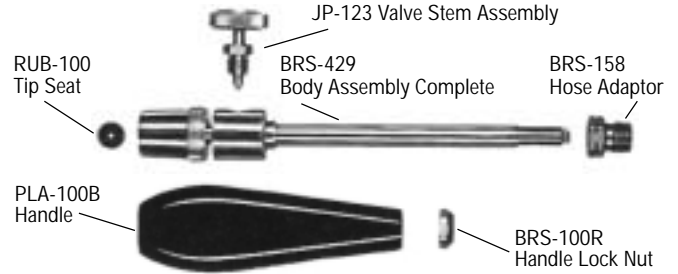

E25 Regulators

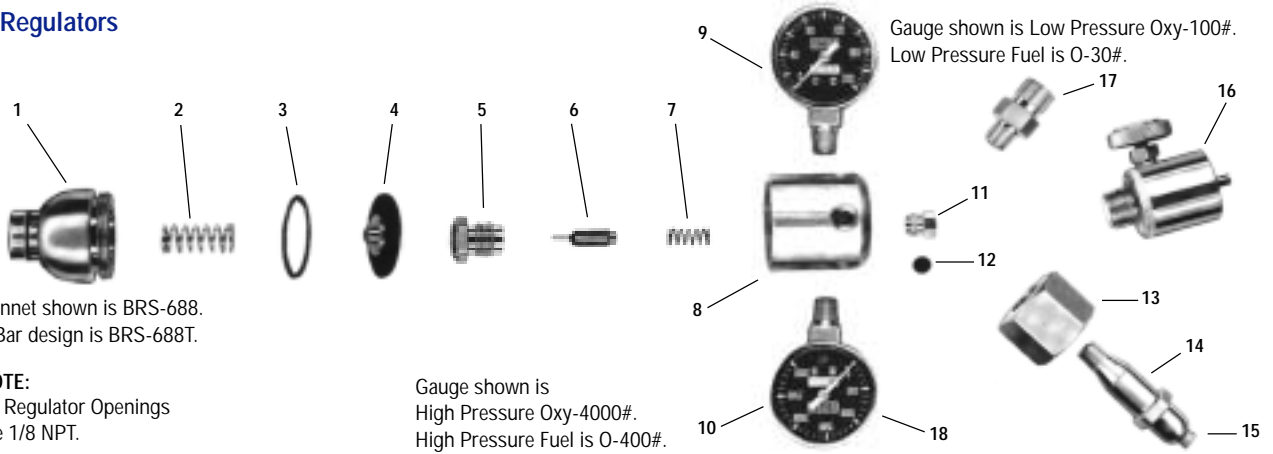

Bonnet shown is BRS-688.
T-Bar design is BRS-688T.

NOTE:
All Regulator Openings
are 1/8 NPT.

Gauge shown is
High Pressure Oxy-4000#.
High Pressure Fuel is O-400#.

Regulator	EA-25-C EA-25-CA Fuel	EA-25-B EA-25-BA Fuel	EA-25-DA EA-25-D Fuel	EA-25-M EA-25-MA Fuel	EA-25 EA-25-A Fuel	EO-25 EO-25-A Oxygen	
1. Bonnet Assembly	BRS-688T	BRS-688T	BRS-688T	BRS-688T	BRS-688T	BRS-688T	
2. Range Spring	STE-143	STE-143	STE-143	STE-143	STE-143	STE-144	
3. Diaphragm Gasket	PLA-104	PLA-104	PLA-104	PLA-104	PLA-104	PLA-104	
4. Diaphragm Assembly	RUB-116	RUB-116	RUB-116	RUB-116	RUB-116	RUB-116	
5. Seat Nut	BRS-282	BRS-282	BRS-282	BRS-282	BRS-282	BRS-282-0	
6. Seat	BRS-411	BRS-411	BRS-411	BRS-411	BRS-411	BRS-411	
7. Seat Spring	STE-170	STE-170	STE-170	STE-170	STE-170	STE-170	
8. Body	BRS-566	BRS-566	BRS-567	BRS-566	BRS-566	BRS-296	
9. Gauge	Low Pressure 1 1/2" Dia. 2" Dia.	STE-146 STE-331	STE-146 STE-331	STE-146 STE-331	STE-146 STE-331	STE-148 STE-357	
10. Gauge	High Pressure 1 1/2" Dia. 2" Dia.	STE-145 STE-332	STE-145 STE-332	STE-145 STE-332	STE-145 STE-332	STE-147 STE-334	
11. Safety Assembly	None Used	None Used	None Used	None Used	None Used	BRS-414	
12. Rupture Disc	None Used	None Used	None Used	None Used	None Used	BRS-291	
13. Inlet Nut	BRS-349	BRS-357	BRS-360	BRS-360	BRS-352	BRS-346	
14. Stem	BRS-345	BRS-359	BRS-361	BRS-361	BRS-343	BRS-344	
15. Filter	STE-172	STE-172	STE-172	STE-172	STE-172	STE-367	
16. Inlet Valve	None Used	None Used	None Used	None Used	None Used	None Used	
17. Outlet	3/8"-24 A Size 9/16"-18 B Size	BRS-382 BRS-328	BRS-382 BRS-328	BRS-382 BRS-328	BRS-382 BRS-328	BRS-381 BRS-329	
18. Gauge Crystal	1 1/2" Dia. 2" Dia.	GC-10 GC-7					

Replacement Tips

Air Products

Airco/Concoa Style # & Sizes	Goss # & Sizes	UPC No. 6 62999
159-00	1476-00	00264 1
159-0	1476-0	00263 4
159-1	1476-1	00265 8
159-2	1476-2	00266 5
159-3	1476-3	00267 2
159-5	1476-5	00269 6

- Acetylene-Oxygen
- Heavy preheat
- For general cutting operations with hand or machine cutting apparatus
- Fits Air Products 2200, 2300, 2400, 6200, 6300 and 6500 torches



Airco/Concoa

Airco/Concoa Style # & Sizes	Goss # & Sizes	UPC No. 6 62999
138-00	840-00	01420 0
138-0	840-0	01419 4
138-1	840-1	01421 7
138-2	840-2	01422 4
138-3	840-3	01423 1
138-4	840-4	01424 8

- Acetylene-Oxygen
- For general cutting operations with hand & machine cutting apparatus
- Light preheat
- Fine contour cutting of plate
- Fits Airco 3790, 4690, 4700, 4800, 5700, 5800, 1100, 3000, 9000, 9500 torches



144-00	820-00	01361 6
144-0	820-0	01360 9
144-1	820-1	01362 3
144-2	820-2	01368 5
144-3	820-3	01369 2
144-4	820-4	01370 8
144-5	820-5	01371 5
144-6	820-6	01372 2
144-7	820-7	01373 9
144-8	820-8	01374 6
144-10	820-10	01363 0

- Acetylene-Oxygen
- For general cutting operations with hand or machine cutting apparatus
- Medium preheat
- Fits Airco 3790, 4690, 4700, 4800, 5700, 5800, 1100, 3000, 9000, 9500 torches



164-00	830-00	01396 8
164-0	830-0	01395 1
164-1	830-1	01397 5
164-2	830-2	01399 9
164-3	830-3	01400 2
164-4	830-4	01401 9
164-5	830-5	01402 6
164-8	830-8	01405 7
164-10	830-10	01398 2

- Acetylene-Oxygen
- Very heavy preheat
- For general cutting, also for use in cutting cast iron and stainless steel
- Fits Airco 3790, 4690, 4700, 4800, 5700, 5800, 1100, 3000, 9000, 9500 torches



Airco/Concoa *Continued*

Airco/Concoa Style # & Sizes	Goss # & Sizes	UPC No. 6 62999
261-00	875-00	01490 3
261-0	875-0	01489 7
261-1	875-1	01491 0
261-2	875-2	01493 4
261-3	875-3	01494 1
261-4	875-4	01495 8
261-5	875-5	01496 5
261-6	875-6	01497 2
261-7	875-7	01498 9
261-8	875-8	01499 6

- Propane or Natural Gas-Oxygen
- Two piece tip for hand cutting
- Heavy preheat, general cutting
- Fits Airco 3790, 4690, 4700, 4800, 5700, 5800, 1100, 3000, 9000, 9500, 2900 torches



263-00	826-00	01382 1
263-0	826-0	01381 4
263-1	826-1	01383 8
263-2	826-2	01385 2
263-3	826-3	01386 9
263-5	826-5	01387 6

- Propane or Natural Gas-Oxygen
- Two piece tip for hand cutting
- Medium preheat, general cutting
- Fits Airco 3790, 4690, 4700, 4800, 5700, 5800, 1100, 3000, 9000, 9500, 2900 torches
- Stinger 275 substitute



Harris

Harris Style # & Sizes	Goss # & Sizes	UPC No. 6 62999
2490VVCМ-4/0	FH-1324-4/0	01870 3
2490VVCМ-000	FH-1324-000	01862 8
2490VVCМ-0	FH-1324-0	01860 4
2490VVCМ-0.5	FH-1324-0.5	01863 5
2490VVCМ-1	FH-1324-1	01864 2
2490VVCМ-2	FH-1324-2	01866 6
2490VVCМ-3	FH-1324-3	01868 0

- MAPP-Oxygen
- Two piece machine cutting
- Thrift Tip
- Fits Harris 98-2 and 93-3 machine torches, and 85 series torches



6290-000	1360-000	00153 8
6290-00	1360-00	00152 1
6290-0	1360-0	00151 4
6290-1	1360-1	00154 5
6290-2	1360-2	00155 2
6290-3	1360-3	00156 9
6290-4	1360-4	00157 6
6290-5	1360-5	00158 3
6290-6	1360-6	00159 0

- Acetylene-Oxygen
- Medium preheat, general hand cutting
- Fits Harris 42-3, 62-3, 72, 72A, 73, 73A, 63-2, and 85 series torches.



6290N-00	1365-00	00177 4
6290N-0	1365-0	00176 7
6290N-1	1365-1	00179 8
6290N-2	1365-2	00180 4
6290N-3	1365-3	00181 1
6290N-4	1365-4	00182 8

- Propane or Natural Gas-Oxygen
- Light preheat for general cutting
- Two piece
- Fits Harris 42-3, 49AF, 49F, 62-3, 85, 72, 73, and 142 series torches.



Replacement Tips

Harris Continued

Harris Style # & Sizes	Goss # & Sizes	UPC No. 6 62999
6290NFF-0	1355-0	00143 9
6290NFF-1	1355-1	00145 3
6290NFF-2	1355-2	00146 0
6290NFF-3	1355-3	00147 7
6290NFF-4	1355-4	00148 4
6290NFF-5	1355-5	00149 1
6290NFF-6	1355-6	00150 7

- Propane or Natural Gas-Oxygen
- Heavy preheat, general cutting
- Two piece
- Fits Harris 42-3, 49AF, 49F, 62-3, 85, 72, 73, and 142 series torches.



6290NX-00	1335-00	00104 0
6290NX-0	1335-0	00103 3
6290NX-1	1335-1	00106 4
6290NX-2	1335-2	00107 1
6290NX-3	1335-3	00108 8
6290NX-4	1335-4	00109 5
6290NX-5	1335-5	00110 1
6290NX-6	1335-6	00111 8

- Propane or Natural Gas-Oxygen
- Medium preheat, general cutting
- Two piece
- Fits Harris 42-3, 49AF, 49F, 62-3, 85, 72, 73, 142 series torches.



6290VVC-5/0	1345-5/0	00138 5
6290VVC-4/0	1345-4/0	00135 4
6290VVC-00	1345-00	00127 9
6290VVC-0	1345-0	00125 5
6290VVC-0.5	1345-0.5	00126 2
6290VVC-1	1345-1	00129 3
6290VVC-1.5	1345-1.5	00130 9
6290VVC-2	1345-2	00131 6
6290VVC-2.5	1345-2.5	00132 3
6290VVC-3	1345-3	00133 0
6290VVC-4	1345-4	00134 7
6290VVC-5	1345-5	00136 1

- Propane or Natural Gas-Oxygen
- High speed tips, for use in machine cutting
- Two piece
- Fits Harris 98-2 and 98-3 machine torches



Marquette Tip

Marquette Style # & Sizes	Goss # & Sizes	UPC No. 6 62999
GW-6-0	1646-0	00329 7
GW-6-1	1646-1	00330 3
GW-6-3	1646-3	00332 7
GW-6-4	1646-4	00333 4

- Acetylene-Oxygen
- General hand and scrap cutting
- Medium preheat
- Fits Marquette 20-110 super jet and 21-110 star jet torches



Meco Tip

Meco Style # & Sizes	Goss # & Sizes	UPC No. 6 62999
LA-00	1556-00	00294 8
LA-0	1556-0	00293 1
LA-1	1556-1	00295 5
LA-2	1556-2	00296 2
LA-3	1556-3	00297 9
LA-4	1556-4	00298 6
LA-5	1556-5	00299 3
LA-6	1556-6	00300 6

- Acetylene-Oxygen
- General cutting
- One piece
- Fits weldmaster, cut master, SCA torches



0 0



0 to 6

Oxweld/Linde/L-Tec

Oxweld/Linde/L-Tec Style # & Sizes	Goss # & Sizes	UPC No. 6 62999
1502-2	1760-2	00405 8
1502-3	1760-3	00406 5
1502-4	1760-4	00407 2
1502-6	1760-6	00408 9
1502-8	1760-8	00409 6
1502-10	1760-10	00403 4

- Acetylene-Oxygen
- Medium preheat
- For hand or machine cutting
- Fits CW-32, C-31, C-23, C-77 hand torches, C-37, C-39, C-58 machine torches



639867	3024-9	01016 5
639868	3024-15	01007 3

- Acetylene-Oxygen
- Complete tip and mixer
- Single flame
- Size 4 to 70 welding
- Size 100 to 250 heating



Purox / Linde / L-Tec

Purox/Linde/L-Tec Style # & Sizes	Goss # & Sizes	UPC No. 6 62999
4202-3	1952-3	00478 2
4202-4	1952-4	00479 9
4202-5	1952-5	00480 5
4202-7	1952-7	00481 2
4202-9	1952-9	00482 9
4202-11	1952-11	00476 8

- Acetylene Oxygen
- Medium preheat for general cutting
- Fits CW-200, CW-202, Type E torches, C-205 machine torch, CW-300 torches



4213-14-3	1955-3	00486 7
4213-14-4	1955-4	00487 4
4213-14-6	1955-6	00488 1
4213-14-8	1955-8	00489 8
4213-14-10	1955-10	00483 6
4213-14-12	1955-12	00484 3

- Propane or Natural Gas-Oxygen
- Two piece
- General cutting
- Complete tip, medium preheat
- Fits CW-200, CW-202, Type E torches
- For MAPP or FG-2 see style P-FS
- For CW-300 torches



P-FS-52	FS-1955-52	01957 1
P-FS-54	FS-1955-54	01958 8
P-FS-56	FS-1956-56	01959 5
P-FS-60	FS-1956-60	01960 1
P-FS-72	FS-1956-72	01963 2

- MAPP or FG-2-Oxygen
- General cutting
- Two piece tip standard speed
- Fits CW-200, CW-202, Type E, CW-300 torches



Rexarc/Rego

Rexarc/Rego Style # & Sizes	Goss # & Sizes	UPC No. 6 62999
KX-6-35	2132-35	00522 2
KX-6-42	2132-42	00523 9
KX-6-46	2132-46	00524 6
KX-6-51	2132-51	00525 3
KX-6-53	2132-53	00526 0
KX-6-56	2132-56	00527 7
KX-6-62	2132-62	00528 4
KX-6-68	2132-68	00529 1

- Acetylene-Oxygen
- Medium preheat for hand cutting
- Fits KXA, SXA, CWP 9000, 7000, 18000, 8720, 6808, 6912, 6916 torches

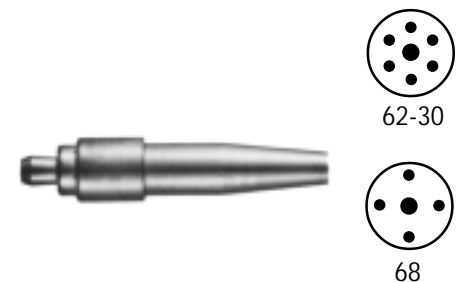

Replacement Tips

Smith

Smith Style # & Sizes	Goss # & Sizes	UPC No. 6 62999
MC12-0	2272-0	00607 6
MC12-1	2272-1	00609 0
MC12-2	2272-2	00610 6
MC12-3	2272-3	00611 3
MC12-4	2272-4	00612 0

- Acetylene-Oxygen
- General cutting
- Medium duty hand cutting
- Fits cutting assemblies Pipeliner MC505, MC509, Airliner AC305, AC309



SC12-00	2276-00	00620 5
SC12-0	2276-0	00619 9
SC12-1	2276-1	00622 9
SC12-2	2276-2	00623 6
SC12-3	2276-3	00624 3
SC12-4	2276-4	00625 0
SC12-5	2276-5	00626 7
SC12-6	2276-6	00627 4

- Acetylene-Oxygen
- For hand or machine cutting
- Fits Silver Star (000-5), Pipeliner MC 409 (000-4)
- Cutting torches Tuf-Tony, Silver Star (000-7)
- Machine torches SC770, SC771, SC780A, SC781A, SC782A (000-7)



Victor

Victor Style # & Sizes	Goss # & Sizes	UPC No. 6 62999
1-101-000	2360-000	00766 0
1-101-00	2360-00	00765 3
1-101-0	2360-1	00764 6
1-101-1	2360-1	00767 7
1-101-2	2360-2	00768 4
1-101-3	2360-3	00769 1
1-101-4	2360-4	00770 7
1-101-5	2360-5	00771 4
1-101-6	2360-6	00772 1
1-101-7	2360-7	00773 8
1-101-8	2360-8	00774 5

- Acetylene-Oxygen
- Medium preheat for hand and machine cutting
- Fits 2460, CA 1060, ST, SST, 1400C machine torches



1-110-00	2361-00	00776 9
1-110-0	2361-0	00775 2
1-110-1	2361-1	00777 6
1-110-2	2361-2	00778 3

- Acetylene-Oxygen
- Drag Type
- Light preheat for plate cutting
- Fits 2460, CA 1060, ST, SST, 1400C machine torches



1-118-0	2368-0	00812 4
1-118-2	2368-2	00814 8
1-118-4	2368-4	00815 5
1-118-6	2368-6	00816 2
1-118-8	2368-8	00817 9

- Acetylene-Oxygen
- Gouging, scarfing and deseaming
- Fits 2460, CA 1060, ST, SST, 1400C torches



3-101-000	2341-000	00696 0
3-101-00	2341-00	00695 3
3-101-0	2341-0	00694 6
3-101-1	2341-1	00697 7
3-101-2	2341-2	00698 4
3-101-3	2341-3	00699 1
3-101-4	2341-4	00700 4
3-101-5	2341-5	00701 1
3-101-6	2341-6	00702 8

- Acetylene-Oxygen
- Medium preheat hand cutting
- Fits CA 1260, CA 1350, C 1450, CA 2060, CST 800, C 1400 torches.



Victor

Victor Style # & Sizes	Goss # & Sizes	UPC No. 6 62999
3-118-2	2348-2	00715 8

- Acetylene-Oxygen
- Gouging-Rivet washing, tip
- Medium preheat
- Fits CA 1260, CA 1350, C 1450, CA 2060, CST 800, C 1400 torches



3-GPN-00	2345-00	00707 3
3-GPN-0	2345-0	00706 6
3-GPN-1	2345-1	00708 0
3-GPN-2	2345-2	00709 7
3-GPN-3	2345-3	00710 3
3-GPN-4	2345-4	00711 0
3-GPN-5	2345-5	00712 7

- Propane or Natural Gas-Oxygen
- Two piece medium preheat series 3 tip
- Fits CA 1260, CA 1350, C 1450, CA 2060, CST 800, C 1400 torches



GPN-000	2355-000	00739 4
GPN-00	2355-00	00738 7
GPN-0	2355-0	00737 0
GPN-1	2355-1	00740 0
GPN-2	2355-2	00741 7
GPN-3	2355-3	00742 4
GPN-4	2355-4	00743 1
GPN-5	2355-5	00744 8
GPN-6	2355-6	00745 5
GPN-8	2355-8	00747 9

- Propane or Natural Gas-Oxygen
- Two piece
- General Cutting
- Medium preheat for hand and machine cutting
- Fits 2450, CA 1060, CAN 1060, ST, SST, STN, 1400C, machine torches



HPN-2	2365-2	00794 3
HPN-3	2365-3	00795 0
HPN-4	2365-4	00796 7

- Propane or Natural Gas-Oxygen
- Two piece
- Scrap cutting, beveling and piercing
- Fits 2450, CA 1060, CAN 1060, ST, SST, STN, 1400C, machine torches



MFA-8	3091-8	01275 6
MFA-10	3091-10	01269 5
MFA-12*	3091-12	01270 1
MFA-15*	3091-15	01271 8

- Acetylene, Propylene, MAPP-Oxygen
- Multiflame nozzle for preheating and straightening
- Fits 300 series torches
- * Use HD 310C torch with 3/8 hose, manifold if acetylene withdrawal rate exceeds 1/7 cylinder content per hour



W-000	3031-000	01070 7
W-00	3031-00	01069 1
W-0	3031-0	01068 4
W-1	3031-1	01071 4
W-2	3031-2	01073 8
W-3	3031-3	01074 5
W-4	3031-4	01075 2
W-8	3031-8	01079 0

- Acetylene-Oxygen
- Complete nozzle (nozzle nut included)
- General welding and preheating
- Fits 300 series torches



W-1-000	3032-000	01083 7
W-1-00	3032-00	01082 0
W-1-0	3032-0	01081 3
W-1-1	3032-1	01084 4
W-1-2	3032-2	01085 1
W-1-3	3032-3	01086 8
W-1-4	3032-4	01087 5
W-1-5	3032-5	01088 2

- Acetylene-Oxygen
- Complete nozzle (nozzle nut included)
- Long cone flame general welding & brazing
- Fits 100 series torches

